

# The influence of integrated information systems on the implementation of advanced managerial accounting techniques

---

Pervan, Ivica; Dropulić, Ivana

*Source / Izvornik:* **Ekonomski vjesnik : Review of Contemporary Entrepreneurship, Business, and Economic Issues, 2020, 33, 382 - 395**

**Journal article, Published version**

**Rad u časopisu, Objavljena verzija rada (izdavačev PDF)**

*Permanent link / Trajna poveznica:* <https://um.nsk.hr/um:nbn:hr:124:550854>

*Rights / Prava:* [Attribution-NonCommercial-NoDerivatives 4.0 International/Imenovanje-Nekomercijalno-Bez prerada 4.0 međunarodna](#)

*Download date / Datum preuzimanja:* **2025-01-15**

*Repository / Repozitorij:*

[REFST - Repository of Economics faculty in Split](#)



**Ivica Pervan**  
University of Split  
Faculty of Economics,  
Business and Tourism  
Cvite Fiskovića 5,  
21000 Split, Croatia  
ivica.pervan@efst.hr  
Phone: +38521430639

**Ivana Dropulić**  
University of Split  
Faculty of Economics,  
Business and Tourism  
Cvite Fiskovića 5,  
21000 Split, Croatia  
ivana.dropulic@efst.hr  
Phone: +38521430773

*Original scientific article*

Received: December 18, 2019  
Accepted for publishing: January 31, 2020

This work is licensed under a  
Creative Commons Attribution-  
NonCommercial-NoDerivatives 4.0  
International License



# THE INFLUENCE OF INTEGRATED INFORMATION SYSTEMS ON THE IMPLEMENTATION OF ADVANCED MANAGERIAL ACCOUNTING TECHNIQUES

## ABSTRACT

The main purpose of this research is to investigate the influence of integrated information systems (IIS) on the use of advanced managerial accounting techniques (AMAT). To analyze this relationship, we employed structural equation modeling (SEM) on empirical data obtained from a sample of 105 Croatian companies. Empirical findings obtained through SEM confirmed a significant positive influence of one of the IIS features, IIS analytical capabilities, on the application of AMAT. Other theoretically interesting independent variables (IIS age, IIS implementation quality, company size, and business environment uncertainty) were also included in the SEM; however, the evaluated SEM failed to provide a good fit to the data, and the parameters were not significant. The findings of this study provide useful guidance for both IIS developers and users, as they indicate that the implementation of IIS with a higher level of analytical capabilities results in a higher level of AMAT use.

**Keywords:** Advanced managerial accounting techniques (AMAT), integrated information systems (IIS), structural equation modeling (SEM), Croatia

## 1. Introduction

In today's digital era, information technology has become an essential part of every business. Two or three decades ago, enterprise resource planning (ERP) applications were the focus of large companies. Today, small and medium-sized enterprises (SMEs) also use globally or locally developed ap-

plications to streamline business processes and improve performance. According to the recent research by Panorama Consulting (2018)<sup>1</sup>, 67% of ERP users reported that they were "very satisfied" or "satisfied" with ERP implementation. The research also revealed that 73% of companies went through "moderate" or "intense" organizational changes during ERP implementation. Such em-

pirical findings confirm theoretical expectations that ERP implementation is an important trigger for changes throughout an organization, including managerial accounting practices. Thus, over the last decade, “scientific literature has given more attention to ERP in the accounting context” (Sardo, Alves, 2018).

ERP applications integrate all business information in a centralized database that enables a company to manage and coordinate all of its information, resources and functions from that database (Gullkvist, 2013). Therefore, ERP applications represent a necessary tool for companies to survive in a very competitive business environment (Spathis, Constantinides, 2003) that requires more integrated, comprehensive and real-time operational information from all organizational units (Eker, Aytaç, 2016). Implementation of ERP applications, whether successful or not, will affect various divisions and individuals in organizations, especially managerial accounting and managerial accountants (Etemadi, Kazeminia, 2014). According to previous research, ERP applications are changing the managerial accounting by providing managers with easy and quick access to relevant and real-time business information required for decision-making (Kallunki et al., 2011; Appelbaum et al., 2017). Pervan and Dropulić (2019) reported that integrated information systems (IIS) application resulted in changes in managerial accountants’ skills and work in several areas (improved knowledge of business processes, improved IT skills, improved communication skills, and reduced time required for the collection of data). Therefore, “the role of the management accountant has shifted from capturing and recording transactions to analyzing business issues” (Sprakman et al., 2015). It is indisputable that the ability of the information systems to merge or substitute different tasks of accountants will consequently change the nature of their job (Fernandez et al., 2018).

Although there has been a growing interest in the subject, research that examines the effects of ERP applications on advanced managerial accounting techniques (AMAT) is still scarce (Booth et al., 2000; Granlund, Malmi, 2002; Scapens, Jazayeri, 2003; Granlund, 2007; Galani et al., 2010; Vakalofotis et al., 2011). Previously mentioned studies have identified only minimal effects of different ERP soft-

ware on managerial accounting techniques. Despite the limited use of AMAT, ERP applications could increase the users’ knowledge about these modern techniques, which can be a good starting point for their future adoption (Gullkvist, 2013). Today, when modern ERP solutions provide organizations with integrated, reliable and, in some cases, real-time data, one can hypothesize that companies will be motivated to adopt these advanced techniques so as to provide managers with higher information quality.

This study contributes to the body of knowledge since it represents one of the very rare studies that explore the influence of IIS use on the adoption of AMAT in Croatia and in South East European (SEE) countries in general. In comparison with early studies, the focus of current research is not exclusively on ERP as all analytical applications are included in IIS measurement. Namely, in business practice, companies often use specialized applications for different areas like budgeting, consolidation of financial statements, managerial reporting, costing, etc., in addition to ERP. Therefore, to capture the IIS variable more comprehensively and precisely, we followed the approach of Rom and Rohde (2006) and defined IIS as a combination of ERP and other specialized analytical applications, which are often called BoB (Best of Breed). To obtain a deeper insight into the IIS variable, we originally developed several IIS features (analytical capabilities, age and implementation quality) that may have a significant influence on the adoption of AMAT.

By using structural equation modeling (SEM), this study improves the research methodology in comparison with the previous literature. Although, SEM has many similarities with linear regression, it has some advantages and thus provides more reliable findings. SEM reveals relationships among hidden structures, which cannot be directly measured. In contrast to regression analysis, which assumes no measurement error, possible mistakes in the measurement of the observed variables are taken into account (Civelek, 2018). Empirical findings from this study confirm that IIS analytical capabilities positively affect the application of AMAT. The rest of this paper is divided into four sections. The following section, Section 2, gives an overview of the relevant early and recent literature. Section 3 provides

information on the statistical methodology used, the questionnaire and research variables. Empirical findings are reported in Section 4, and concluding remarks are presented in Section 5.

## 2. Literature review and theoretical model

Information technology facilitates the automation of business processes (Sangster et al., 2009) and involves improving information access and coordination across organizational units (Attaran, 2004) like production, sales and marketing, finance and accounting. This, in turn, creates a firmly integrated system with a continuous stream of information through the whole organization (Galani et al., 2010). Previous researchers have identified only minimal effects of different ERP software on the introduction of new AMAT (Booth et al., 2000; Granlund, Malmi, 2002; Scapens, Jazayeri, 2003; Granlund, 2007; Galani et al., 2010; Vakalftotis et al., 2011). In an early study, Granlund and Malmi (2002) examine the effects of integrated, enterprise-wide information systems on managerial accounting and managerial accountants' work on the sample of ten companies from Finland. The results of that study show that, in most of the cases, AMAT and several traditional techniques are supported by applications separate from ERP. Considering the effect of ERP on managerial accounting techniques, it was found that it did not influence companies' decisions to apply activity-based costing (ABC). Although ERP provides some of the information contained in the balanced scorecard (BSC), ERP applications were not found to have a significant impact on the deployment of the BSC because the BSC is maintained outside the ERP.

Booth et al. (2000) analyzed the influence of ERP applications on the implementation of new accounting practices, degree of information system integration and related benefits that Australian companies believe they have accomplished. The results indicate that ERP applications have little influence on the implementation of AMAT. In another study, Scapens and Jazayeri (2003) found that there have been no fundamental changes in the character of the managerial accounting information, and no new "sophisticated" managerial accounting techniques have been deployed after the implementation of the SAP system, as the most advanced ERP system, in the European branch of a large US multinational organization. Rom and Rohde (2006)

explored the link between IIS and managerial accounting practices and found that AMAT including the use of non-financial information is better supported by a strategic enterprise management system. Malinić and Todorović (2012) surveyed nine Serbian companies (which adopted SAP) and found that managerial accounting techniques did not significantly change under the influence of SAP. Nevertheless, SAP is a significant source of support to the new managerial accounting practices. Moreover, it is realistic to expect that in the future SAP will influence the introduction of new and support the changes in the current managerial accounting practices.

Although organizations may have other reasons for the application of ERP, Gullkvist (2013) indicated that, to some extent, the organizations implemented AMAT after the ERP implementation and that the most commonly adopted modern techniques were key performance indicators (KPIs). Also, the use of other modern practices such as Activity-Based Costing (ABC), Target Costing (TC) and the BSC appears to have increased, although to a smaller degree. Utilizing the ERP system, organizations can coordinate themselves with AMAT such as ABC and forecasting that have been strongly supported by the ERP system (Hosseinzadeh, Davari, 2018). Eker and Aytaç (2017) examine how AMAT such as ABC, BSC, TC and etc. become effective with the support of the ERP system and how this interaction influences organizational performance. They concluded that the high level of interaction between ERP and AMAT is associated with high financial and non-financial performance. According to Wajdi (2018), accounting techniques used after the implementation of ERP systems can affect the performance of organizations amounting to 68.5%.

This study provides an insight into how IIS implementation contributes to the introduction of AMAT. As mentioned earlier, the main aim of this study was to examine the effect of IIS on the application of AMAT. The age of IIS (IIS\_AGE), IIS analytical capabilities (ISS\_AC) and perceived quality of IIS implementation (ISS\_IQ) were the independent variables, and ABC, BSC, TC, benchmarking (BENCH) and KPIs were the dependent variables. Business environment uncertainty and company size were used as company characteristics. The model presented in Figure 1 includes all relations examined in this research.

Figure 1 Theoretical model

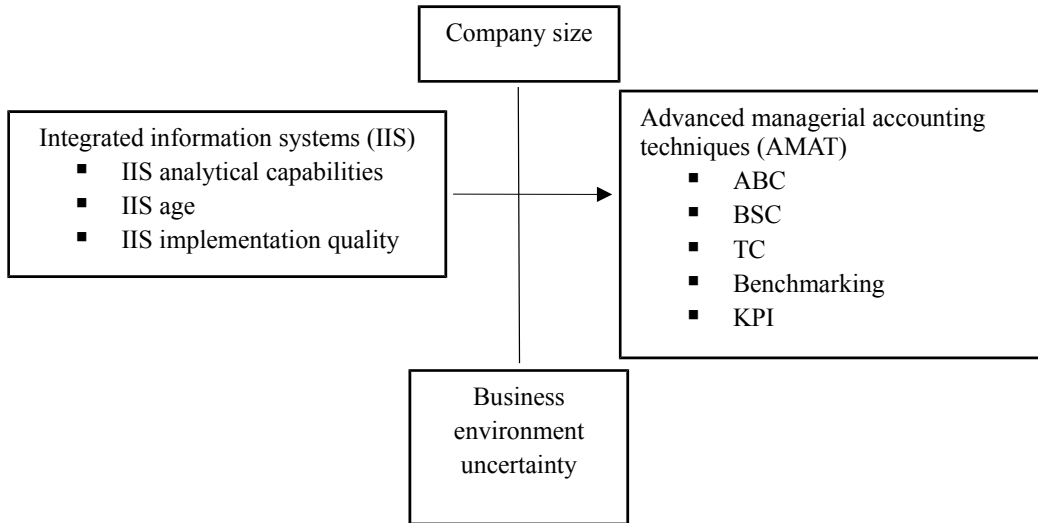

Source: Authors

Although the results of previous research are not entirely consistent, some researchers claim that a precondition for getting AMAT to work in organizations appears to be connecting them with information technology or, more precisely, with IIS. Based on extant theory and research evidence, we expect a positive relationship between IIS and AMAT.

### 3. Research methodology

The empirical data were collected in 2018 by means of a questionnaire sent to 500 randomly selected Croatian companies that use IIS. An e-mail with a link to the online questionnaire was sent to finance managers, business controllers, heads of accounting departments and equivalent job positions because they were expected to have sufficient information about the effect of IIS use on the application of AMAT. In all, 133 questionnaires were filled out, and the response rate was 26.6%. Among the 133 questionnaires filled out, 28 were incomplete. Consequently, only 105 questionnaires were used for modeling purposes. In comparison with previous empirical studies (Booth et al., 2000; Hyvonen,

2003; Sangster et al., 2009; Gullkvist, 2013), which were based on samples comprising between 30 and 99 companies, the sample size of 105 observations was respectable. Regarding the use of the structural equation model, some authors (Ding et al., 1995) suggested at least 100 observations. However, Bentler and Chou (1987) suggested that in the case of non-normally distributed data, there should be at least 10 observations per variable. Since our final structural equation model is based on 10 variables (8 observed and 2 latent), the requirement regarding the sample size according to the number of research variables was also satisfied.

The questionnaire included items that were required for measuring variables (Table 1) of our interest - adoption of AMAT (dependent variable) and five independent variables, IIS analytical capabilities, IIS age, IIS implementation quality, company size and business environment uncertainty. It is important to point out that the majority of variables (except IIS age and company size) used for modeling represent latent variables, which are measured by at least three observable variables as recommended by the literature (Civelek, 2018).

**Table 1** List of variables used in modeling

Variable	Measurement
Advanced managerial accounting techniques (AMAT)	Likert scale (1 to 5)
IIS analytical capabilities (IIS_AC)	Likert scale (1 to 5)
IIS age (IIS_AGE)	In years
IIS implementation quality (IIS_IC)	Likert scale (1 to 5)
Company size (SIZE)	Four groups according EU rules
Business environment uncertainty (BEU)	Likert scale (1 to 5)

Source: Authors

In the initial phase of modeling, comprehensive models, including all potentially interesting independent variables, were estimated. However, the fit of the estimated structural models was not at a satisfactory level (details on the criteria for the evaluation of structural model fit are given in Table 6), and the estimated parameters were not statistically significant. In addition to paper length restrictions this is why only the constructs that were included into the final model (AMAT and IIS\_AC) are described in detail. Questionnaire items that were used for measuring AMAT were selected based on variables that were used in similar studies (Booth et al., 2000; Malinić, Todorović, 2012; Gullkvist, 2013). Respondents were asked to evaluate how IIS implementation affected the adoption of the following five advanced techniques: ABC, BSC, TC, BENCH and KPIs. However, the measurement model for the AMAT construct confirmed that the construct with four items (BSC, TC, BENCH and KPI) has an acceptable fit to the data. The AMAT construct that included ABC did not provide an acceptable fit since the main fit indices were not at required levels (Root mean square error of approximation - RMSEA = 0.202; CMIN/DF = 5.379; Tucker-Lewis index - TLI = 0.899, etc.).

Before we evaluated the final SEM, it was necessary to test the reliability and convergent validity for the developed constructs. Internal reliability of the used measurement scale is often evaluated based on Cronbach's alpha, which should be greater than 0.7 (Civelek, 2018). Cronbach's alphas for the developed constructs in this research were 0.940 and 0.846 (Table 2), confirming the reliability of the measurement model. An additional indicator that should be considered is the composite reliability - CR from confirmatory factor analysis, which indicates the consistency of each developed construct. One can conclude that the composite reliability of the construct is adequate if the CR value is higher than 0.7. In the case of AMAT and IIS\_AC constructs, consistency was confirmed since the values were 0.958 and 0.896, respectively. Finally, average variance extracted - AVE represents the sum of variance related to the developed construct relative to the sum due to measurement error. The literature (Fornell and Larcker, 1981) suggests that AVE should be higher than 0.5, which was the case for both constructs, AMAT and IIS\_AC. The simultaneous analysis of the CR and AVE values indicated that convergent validity was established.

**Table 2** Indicators of reliability and convergent validity

Construct	Indicator	Cronbach's Alpha	CR	AVE
AMAT	KPI	0.940	0.958	0.849
	BENCH			
	TC			
	BSC			
IIS_AC*	IIS_DASHBO	0.846	0.896	0.684
	IIS_DMING			
	IIS_PR_REALT			
	IIS_FORCAST			

\*IIS\_AC represent the use of dashboards, datamining, real-time project reporting and forecasting

Source: Authors' calculation

Like regression analysis, structural models have several assumptions. The first assumption is that there is multivariate normality of the observed variables, which is often violated when ordinal and discrete scales are used (Civelek, 2018). Violation of normality assumptions leads to a high CMIN/DF value and a significant test outcome. Univariate normality can be evaluated based on skewness and kurtosis, both of which should be below 3.0. There was evidence of

univariate normality for the items used for AMAT and IIS\_AC constructs since all values were under 3.0 (Table 3). However, in the case of multivariate normality, there was a violation of normality assumption since the multivariate kurtosis value was higher than 5, i.e. the critical value was higher than 1.96. Evidence of non-normal distribution required the application of the bootstrapping technique when evaluating the structural model.

**Table 3 Evaluation of variables normality**

Variable	Min.	Max.	Skewness	C.R.	Kurtosis	C.R.
KPI	1	5	0.010	0.040	-1.337	-2.796
BENCH	1	5	0.289	1.209	-1.130	-2.363
TC	1	5	0.086	0.359	-1.121	-2.345
BSC	1	5	0.196	0.822	-1.250	-2.614
IIS_DASHBO	1	5	0.473	1.981	-1.068	-2.234
IIS_DMINING	1	5	0.380	1.591	-1.058	-2.214
IIS_PR_REALT	1	5	0.176	0.737	-1.177	-2.463
IIS_FORCAST	1	5	0.185	0.773	-1.278	-2.672
Multivariate					25.428	10.299

Source: Authors' calculation

Additionally, we had to test for potential outliers in the data distribution. IBM SPSS 23 Amos software supports outlier identification by using the Mahalanobis distance. All observations with a p1 value higher than 0.05 indicate outliers, which, in our sample, was the case for 10 of our observations (Table 4). At this point in our research, it was

necessary to decide what to do with the identified outliers. The fact that outliers exist is not in itself a justification for outlier elimination. Moreover, after removing the first cycle of outliers, additional checks may reveal a new set of outliers. Therefore, we decided to keep all 10 identified outliers, which represented 9.5% of the sample in our research.

**Table 4 Evaluation of Mahalanobis distance**

Observ. No.	Mahalanobis d-Squared	p1	p2
67	37.716	0.0001	0.0010
78	29.874	0.0001	0.0001
19	26.233	0.0010	0.0001
23	21.975	0.0050	0.0020
24	21.643	0.0060	0.0000
97	20.153	0.0100	0.0010
82	20.078	0.0100	0.0001
98	19.932	0.0110	0.0001
42	19.068	0.0150	0.0001
32	16.372	0.0370	0.0060
54	15.024	0.0590	0.0440

Source: Authors' calculation

An additional assumption of the structural model is that there is no correlation among independent variables in the structural equation model, i.e. multicollinearity is not an issue. To test for the presence of multicollinearity, we used variance inflation fac-

tors (VIF), which have a critical value of 5. Since all VIF values from the auxiliary regression model were below 5, there was no evidence of multicollinearity among the observed independent variables (Table 5).

**Table 5 Evaluation of multicollinearity for the observed independent variables**

Item	Tolerance	VIF
IIS_DASHBO	0.524	1.907
IIS_DMINING	0.553	1.810
IIS_PR_REALT	0.545	1.834
IIS_FORCAST	0.501	1.996

Source: Authors' calculation

#### 4. Research findings

Using the maximum likelihood estimation, supported by IBM SPSS Amos 23, we evaluated the SEM parameters. The evaluated structural equation model should have a good empirical data fit. Goodness of model fit can be evaluated with different indices. Relevant statistical literature (Schreiber et al., 2006; Schumacker, Lomax, 2010; Teo et al., 2013; Civelek, 2018) suggests the use of chi-square, CMIN/DF, goodness-of-fit index (GFI), TLI, comparative fit index (CFI), normed fit index (NFI), RMSEA, etc. In this model, the absolute measure of data fit of chi-square was 31.25 (p-value of 0.038). The ideal value for chi-square is zero, while the p-value should be insignificant (higher than 0.05). However, since chi-square is related to the size of research sample and many SEM-based studies reported a significant chi-square, Byrne (2016) sug-

gested that this indicator should be analyzed simultaneously with other model fit indices (Table 6). For example, if the chi-square value (31.25) is divided by the degrees of freedom (DF = 19), the calculated CMIN/DF value equals 1.645, which represents a good fit since the desired value is lower than 3 (Schreiber et al., 2006; Civelek, 2018).

The GFI represents the absolute measure of model fit, which indicates the degree of variance and covariance explained by the evaluated SEM. The GFI increases with the increase in sample size (Teo et al., 2013). The GFI for the model that was estimated in this research equaled 0.935, which indicates an acceptable fit. RMR (Root Mean Square Residual) represents overall badness-of-fit measure and calculated RMR value (0.047) was lower than critical value of 0.05 indicating a good data fit.

**Table 6 Model fit indices**

Fit indices	Calculated indices value*	Good fit value**	Acceptable fit value**
Chi square p-value	0.038	>0.05	-
CMIN/DF	1.645	<3.0	-
RMR	0.047	<0.05	<0.08
GFI	0.935	>0.95	>0.90
TLI	0.974	>0.95	>0.90
CFI	0.982	>0.95	>0.90
IFI	0.982	>0.95	>0.90
NFI	0.956	>0.95	>0.90
RMSEA	0.079	<0.05	<0.08

Source: \* Authors' calculation; \*\* compiled from Schreiber et al. (2006); Schumacker and Lomax (2010); Teo et al. (2013); Civelek (2018)



In contrast to GFI, other indices such as TLI, CFI and NFI are comparative fit indices, which compare alternative models and provide information on the degree of model fit. According to the TLI, which compares the research model with the null model, a good fit is obtained when the TLI value reaches the value of one. According to Schumacker and Lomax (2010), the lower threshold for the TLI starts at 0.90, and therefore, the estimated model TLI value of 0.974 represents a good fit. The CFI compares the research model with the independence model, and a value of 0.90 is considered acceptable fitting. Since the calculated value of CFI equaled 0.982, it represents a good fit, and similar findings of a good fit were obtained for incremental fit index (IFI) and NFI. Regarding the model fit, special attention should be given to RMSEA, which compares the mean differences of each expected degree of freedom that may occur in the population. A RMSEA value below 0.05 is regarded as a good fit, while a RMSEA value below 0.08 represents an acceptable fit, which was the case for the estimated model. In summary, based on the described results, goodness

of model fit can be regarded as acceptable or good for the vast majority of standard fit indices. Finally, it is of note that in unstandardized estimates the error variance in AMAT variable equals 0.12, which is a very low value. In standardized estimates, calculated  $R^2$  is very high since 89% of variance in the AMAT is explained by IIS\_AC.

As mentioned earlier, the main SEM assumption of multivariate normality was not met; therefore, our solution was to perform the bootstrapping technique. Bootstrapping results in creating sub-samples and evaluating the accuracy of predicted parameters by looking at the distribution of parameters computed from each sub-sample (Civelek, 2018). Formal testing of the evaluated structural model was done using the Bollen-Stine goodness-of-fit measure (Bollen and Stine, 1992), for which the p-value should be insignificant ( $>0.05$ ). Since the calculated p-value was 0.335, we can conclude that the evaluated SEM fits the data well, even in this sample with non-normally distributed data.

Figure 2 Structural model – standardized estimates

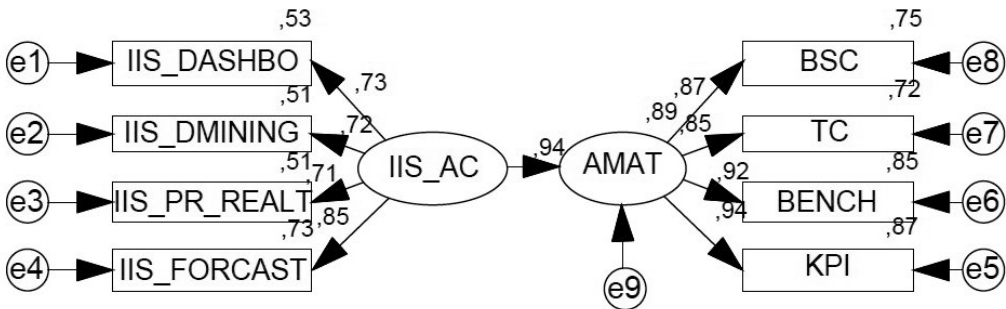

Source: Authors

The inspection of the parameter estimates revealed that all of them were consistent with theoretical expectations (Table 7). All items that formed AMAT and IIS\_AC constructs had a positive sign, while critical values, which operated as z-statistics, exceeded  $\pm 1.96$ , which indicated statistically significant parameters. To be more precise, all estimated parameters were significant at

the 1% level. In addition, the focus of this study, the expected influence of IIS main feature IIS\_AC on AMAT, was confirmed to be positive and significant. In other words, in line with theoretical expectations, empirical data for Croatian companies revealed that the IIS analytical capabilities were positively influencing the implementation of AMAT.

**Table 7 Evaluated model regression weights**

Parameter			Unstand. Estimate	S.E.	C.R.	P	Stand. Estimate
AMAT	<---	IIS_AC	0.896	0.088	10.133	***	0.945
IIS_FORCAST	<---	IIS_AC	1.000				0.854
IIS_PR_REALT	<---	IIS_AC	0.819	0.098	8.324	***	0.713
IIS_DMINING	<---	IIS_AC	0.800	0.096	8.369	***	0.716
IIS_DASHBO	<---	IIS_AC	0.833	0.097	8.586	***	0.729
BENCH	<---	AMAT	1.153	0.083	13.877	***	0.925
KPI	<---	AMAT	1.242	0.087	14.219	***	0.935
BSC	<---	AMAT	1.000				0.866
TC	<---	AMAT	1.003	0.088	11.726	***	0.851

\*\*\* Values lower than 0.001

Source: Authors' calculation

After the bootstrap technique was applied with 500 usable bootstrap samples, it was possible to evaluate the lower and upper bound for each estimated parameter. Since all lower and upper parameter bounds remained positive and the calculated p-values were less than 0.05, it can be stated that, despite non-normally distributed data, the estimated parameters showed a high level of stability. Regression weight, i.e. the parameter of IIS\_AC influence on AMAT, had an upper bound of 1.059 and a lower bound of 0.750 (Table 8).

**Table 8 Evaluated model regression weight intervals - bootstrap technique**

Parameter			Estimate	Lower	Upper	P
AMAT	<---	IIS_AC	0.896	0.750	1.059	0.003
IIS_FORCAST	<---	IIS_AC	1.000	1.000	1.000	...
IIS_PR_REALT	<---	IIS_AC	0.819	0.628	0.994	0.004
IIS_DMINING	<---	IIS_AC	0.800	0.621	0.979	0.003
IIS_DASHBO	<---	IIS_AC	0.833	0.592	1.057	0.006
BENCH	<---	AMAT	1.153	1.028	1.293	0.005
KPI	<---	AMAT	1.242	1.097	1.422	0.004
BSC	<---	AMAT	1.000	1.000	1.000	...
TC	<---	AMAT	1.030	0.863	1.206	0.005

Source: Authors' calculation

The empirical findings from our research conducted on a sample of Croatian companies conflict with findings from some early studies (Booth et al., 2000; Granlund, Malmi, 2002). However, the findings are consistent with the theoretical expectations and results of some recent research. The findings on the positive influence of IIS analytical capabilities on the application of AMAT are comparable with findings for Serbian companies (Malinić, Todorović, 2012) and Finnish companies (Gullkvist, 2013). Although, IIS\_AC is constructed differently in comparison with the above-mentioned recent studies, the basic logic is similar. If the implemented IIS

contains the appropriate analytical tools, one can expect a positive influence on AMAT. In contrast, if the implemented IIS is primarily transaction oriented (data collection, data processing, data storing, automated reporting, etc.) and there are no ERP or BoB analytical functionalities, there is no impetus for the adoption of AMAT. To be more precise, the AMAT construct in the surveyed Croatian companies included the use of four techniques: BSC, TC, BENCH and KPIs. The only technique that was excluded from the AMAT construct was ABC, since the measurement model that included ABC was a poor fit for the data.

## **5. Conclusion**

In the 21<sup>st</sup> century, business operations are brimming with large amounts of information that are created in the business environment and within companies. To provide managers with high-quality information during the last few decades, advanced management accounting techniques (AMAT) have emerged. During the same time span, many companies started to use integrated information systems (IIS) with the aim of improving business processes and performance. IIS should support managerial accounting tasks and enable the application of AMAT. However, in the literature, there is no clear evidence that IIS really facilitates the adoption of AMAT. In order to explore this relationship, we have collected data from 105 Croatian companies and applied SEM. After an assessment of different structural equation models, the final one included two constructs, AMAT and IIS\_AC, which the study focused on. In line with theoretical

expectations, the estimated parameters confirmed that IIS analytical capabilities (represented by use of dashboards, datamining, real-time project reporting and forecasting) positively influenced the use of AMAT. Such a conclusion represents useful guidance for both IIS developers and users because it indicates that special attention should be given to implementing a high level of the IIS analytical capabilities. In addition to the obtained results, we should also highlight some limitations of the research. Although the research sample was fairly large, an increase in the number of observations may improve SEM modeling and the design of a more comprehensive model which could include more variables, covariances among variables and path analysis. In addition, since there is a learning curve and more time may be needed for the more advanced use of IIS capabilities, future longitudinal research, including AMAT variables with time lag, may be beneficial.

## REFERENCES

1. Appelbaum, D., Kogan, A., Vasarhelyi, M., Yan, Z. (2017), "Impact of business analytics and enterprise systems on managerial accounting", *International Journal of Accounting Information Systems*, Vol. 25, pp. 29-44.
2. Attaran, M. (2004), "Exploring the relationship between information technology and business process reengineering", *Information & Management*, Vol. 41, No. 5, pp. 529-684.
3. Bentler, P. M., Chou, C. (1987), "Practical Issues in Structural Modeling", *Sociological Methods and Research*, Vol. 16, No. 1, pp. 78-117.
4. Booth, P., Matolcsy, Z., Wieder, B. (2000), "The impacts of enterprise resource planning systems on accounting practice – the Australian experience", *Australian Accounting Review*, Vol. 16, No. 1, pp. 4-18.
5. Bollen, K. A., Stine, R. A. (1992), "Bootstrapping goodness-of-fit measures in structural equation models", *Sociological Methods and Research*, Vol. 21, No. 2, pp. 205-229.
6. Byrne, B. M. (2016). *Structural Equation Modelling with AMOS: Basic Concepts, Applications, and Programming*. 3rd edition. New York, NY: Routledge.
7. Civelek, M. E. (2018). *Essentials of Structural Equation Modelling*. Lincoln, NE: Zea Books.
8. Ding, L., Velicer, W., Harlow, L. (1995), "Effect of estimation methods, number of indicators per factor and improper solutions on structural equation modeling fit indices", *Structural Equation Modeling*, Vol. 2, No. 2, pp. 119-143.
9. Eker, M., Aytac, A. (2016), "Effects Of Interaction Between Erp And Advanced Managerial Accounting Techniques On Firm Performance: Evidence From Turkey", *The Journal of Accounting and Finance*, Vol. 72, pp. 187-209.
10. Eker, M., Aytac, A. (2017), "The Role of ERP in Advanced Managerial Accounting Techniques: A Conceptual Framework", *Business and Economics Research Journal*, Vol. 8, No. 1, pp. 83-100.
11. Etemadi, H., Kazemini, S. (2014), "Impact of Enterprise Resource Planning Systems (ERP) on Management Accountants", *Management and Administrative Sciences Review*, Vol. 3, No. 4, pp. 507-515.
12. Fernandez, D., Zaino, Z., Ahmad, H. (2018), "An Investigation of Challenges in Enterprise Resource Planning (ERP) Implementation: The Case of Public Sector in Malaysia", *International Journal of Supply Chain Management*, Vol. 7, No. 3, pp. 113-117.
13. Fornell, C., Larcker, D. F. (1981), "Evaluating Structural Equation Models with Unobservable Variables and Measurement Error", *Journal of Marketing Research*, Vol. 18, No. 1, pp. 39-50.
14. Galani, D., Gravas, E., Stavropoulos, A. (2010), "The Impact of ERP Systems on Accounting Processes", *International Journal of Economics and Management Engineering*, Vol. 4, No. 6, pp. 774-779.
15. Granlund, M. (2007), "On the Interface between Management Accounting and Modern Information Technology – A literature review and some empirical evidence", available at: <https://ssrn.com/abstract=985074> (Accessed on: October 2, 2018)
16. Granlund, M., Malmi, T. (2002), "Moderate impact of ERPS on management accounting: a lag or permanent outcome?", *Management Accounting Research*, Vol. 13, No. 3, pp. 299-321.
17. Gullkvist, B. M. (2013), "Drivers of change in management accounting practices in an ERP environment", *International Journal of Economic Sciences and Applied Research*, Vol. 6, No. 2, pp. 149-174.
18. Hosseinzadeh, A., Davari, B. (2018), "The Impact of Enterprise Management Systems on Management Accounting in Private Companies of Iran", *International Journal of Economics and Financial Issues*, Vol. 8, No. 1, pp. 83-89.
19. Hyvonen, T. (2003), "Management Accounting and Information Systems: ERP versus Bob", *European Accounting Review*, Vol. 12, No. 1, pp. 155-173.
20. Kallunki, J-P., Laitinen, E. K., Silvola, H. (2011), "Impact of enterprise resource planning systems on management control systems and firm performance", *International Journal of Accounting Information Systems*, Vol. 12, No. 1, pp. 20-39.

21. Malinić, S., Todorović, M. (2012), "How Does Management Accounting Change under the Influence of ERP?", *Economic Research-Ekonomska Istraživanja*, Vol. 25, No. 3, pp. 722-751.
22. Pervan, I., Dropulić, I. (2019), "The Impact of Integrated Information Systems on Management Accounting: Case of Croatia", *Management: Journal of Contemporary Management Issues*, Vol. 24, No. 1, pp. 21-38.
23. Rom, A., Rohde, C. (2006), "Enterprise resource planning systems, strategic management systems and management accounting", *Journal of enterprise information management*, Vol. 19, No. 1, pp. 50-66.
24. Sangster, A., Leech, S. A., Grabski, S. (2009), "ERP implementations and their impact upon management accountants", *Journal of Information Systems and Technology Management*, Vol. 6, No. 2, pp. 125-142.
25. Sardo, F., Alves, M. C. (2018), "ERP Systems and Accounting: A Systematic Literature Review", *International Journal of Enterprise Information Systems*, Vol. 14, No. 3, pp. 1-18.
26. Scapens, R., Jazayeri, M. (2003), "ERP systems and management accounting change: opportunities or impacts? A research note", *European Accounting Review*, Vol. 12, No. 1, pp. 201-233.
27. Schreiber, J. B., Stage, F. K., King, J., Nora, A., Barlow, E. A. (2006), "Reporting Structural Equation Modeling and Confirmatory Factor Analysis Results: A Review", *The Journal of Educational Research*, Vol. 99, No. 6, pp. 323-337.
28. Schumacker, R. E., Lomax, R. G. (2010). *A Beginner's Guide to Structural Equation Modeling*. 3rd edition. New York, NY: Routledge.
29. Spathis, C., Constantinides, S. (2003), "The usefulness of ERP systems for effective management", *Industrial Management and Data Systems*, Vol. 103, No. 9, pp. 677-685.
30. Spraakman, G., O'Grady, W., Askarany, D., Akroyd, C. (2015), "Employers' Perceptions of Information Technology Competency Requirements for Management Accounting Graduates", *Accounting Education*, Vol. 24, No. 5, pp. 403-422.
31. Teo, T., Tsai, L. T., Yang, C. C. (2013), "Applying Structural Equation Modeling (SEM) in Educational Research: An Introduction", in Khine, M. S. (Ed.), *Application of Structural Equation Modeling in Educational Research and Practice*, Sense Publishers, Rotterdam, pp. 3-21.
32. Vakalftotis, N., Ballantine, J., Wall, A. (2011), "A Literature Review on the Impact of Enterprise Systems on Management Accounting", paper presented at the 8<sup>th</sup> International Conference on Enterprise Systems, Accounting and Logistics (8<sup>th</sup> ICESAL 2011), Thassos Island, July 11-12, 2011, pp. 79-105.
33. Wajdi, F. (2018), "The Role Of Management Accounting Practices In The Use Of The Mediate Relation The Quality Of Information And The Quality Of An Erp System On Performance Of Companies In Indonesia", *Akuntabilitas: Jurnal Ilmu Akuntansi*, Vol. 11, No. 2, pp. 257-280.

## ENDNOTES

- <sup>1</sup> Panorama Consulting (2018), "ERP report", available at: <https://cdn2.hubspot.net/hubfs/2184246/2018%20ERP%20Report.pdf> (Accessed on: October 11, 2019)

*Ivica Pervan*

*Ivana Dropulić*

## **UTJECAJ INTEGRIRANIH INFORMACIJSKIH SUSTAVA NA IMPLEMENTACIJU SUVREMENIH TEHNIKA MENADŽERSKOG RAČUNOVODSTVA**

### **SAŽETAK**

Svrha je ovoga rada istražiti utjecaj integriranih informacijskih sustava (IIS) na implementaciju suvremenih tehnika menadžerskog računovodstva (AMAT). Da bi se analizirao navedeni odnos, primijenjeno je strukturalno modeliranje (SEM) na podacima prikupljenim od 105 kompanija iz Republike Hrvatske. Empirijski rezultati primjenom SEM-a potvrdili su pozitivan i značajan utjecaj jedne od karakteristika IIS-a, analitičke sposobnosti IIS-a na implementaciju AMAT-a. Ostale teorijski zanimljive nezavisne varijable (starost IIS-a, kvaliteta implementacije IIS-a, veličina kompanije i neizvjesnost poslovnog okruženja) također su bile uključene u SEM, međutim, procijenjeni SEM nije osigurao prihvatljivu razinu poklapanja s podacima. Rezultati ovoga istraživanja pružaju korisne smjernice i za dobavljače IIS-a i za njihove korisnike, te ukazuju da će implementacija IIS-a koji uključuje višu razinu analitičkih sposobnosti rezultirati višom razinom implementacije AMAT-a.

**Ključne riječi:** suvremene tehnike menadžerskog računovodstva (AMAT), integrirani informacijski sustavi (IIS), strukturalno modeliranje (SEM), Hrvatska